



E Series Stationary Compactors

PRODUCT SHEET

Dimensions by model

Model	A	B	C	D	E	F	G	I	J	K	L	M	N	O
E240	39	64.5	115	54.5	48.5	27	56.5	30.5	15	N/A	N/A	63.5	81.25	30.25
E300	42	64.5	132	57.5	52	30	56.5	30.5	15	N/A	51.75	73.25	81.25	30.25
E400	60	64.5	167	57.5	52	30	56.5	30.5	15	48.5	55	55	81.25	30.25
E600	98	64.5	256	57.5	52	30	56.5	30.5	15	115	67	67	81.25	30.25

Specifications

	E240	E300	E400	E600
Manufacturer Rating	1.4 c/y	2.45 c/y	3.0 c/y	5.04 c/y
Volume Displacement/Hour	151 c/y	129 c/y	157 c/y	156 c/y
Hopper - Clear Top Opening	39" x 56.5"	42" x 56.5"	60" x 56.5"	98" x 57.5"
Overall Length	115"	132"	167"	256"
Overall Height	48.5"	52"	52"	52"
Overall Width	81.25"	81.25"	81.25"	81.25"
Ram Face Size	27" x 59.125"	30" x 59.125"	30" x 59.125"	30" x 59.125"
Ram Penetration	12"	12"	16"	16"
Normal Ram Force	41,000 lbs.	56,548 lbs.	56,548 lbs.	56,548 lbs.
Maximum Ram Force	45,000 lbs.	65,548 lbs.	65,030 lbs.	65,030 lbs.
Normal Ram Face Pressure	12.5 psi	32 psi.	32 psi.	32 psi.
Maximum Ram Face Pressure	14 psi	37 psi.	37 psi.	37 psi.
System Pressures	2000-2300 psi (max)	2000-2300 psi (max)	2000-2300 psi (max)	2000-2300 psi (max)
Cycle Time	38 seconds	64 seconds	64 seconds	105 seconds
Cylinder	5" bore x 54" stroke	6" bore x 60" stroke	6" bore x 72" stroke	6" bore x 120" stroke
	w/ 3" Chrome Shaft	w/ 3" Chrome Shaft	w/ 3" Chrome Shaft	w/ 3" Chrome Shaft
Floor	3/8" plate	3/8" plate	3/8" plate	3/8" plate
Slides	1/4" plate	1/4" plate	1/4" plate	1/4" plate
Ram Force	3/8" plate	3/8" plate	3/8" plate	3/8" plate
Top Cover	10 gauge	10 gauge	10 gauge	10 gauge
Ram Guide System	Abrasive Resistant Steel	Abrasive Resistant Steel	Abrasive Resistant Steel	Abrasive Resistant Steel
Compactor Weight	Approx. 4,100 lbs.	Approx. 4,600 lbs.	Approx. 4,600 lbs.	Approx. 4,600 lbs.

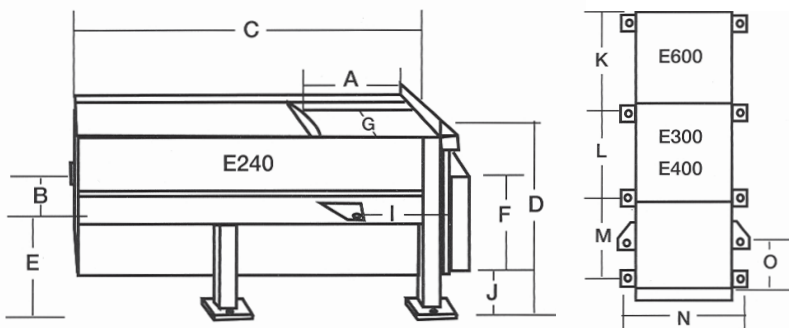

POWER PACK UNIT

Pump 11 GPM @1800 RPM

Reservoir 22 gallon

Solenoid Valve, Standard Pressure Relief Valve

Standard Full / Jam Light, Standard Oil Sight Gauge

Key Operated Remote Power Unit

Model E400 and E600 take a 15HP power unit

Push Button Controls

Cycle Control by timer or magnetic limit switch

Electric Motor - 208, 230, 460 (3 phase)

Motor of High torque Hyd. 10 HP TEFC

Power Unit Weight Approximate 535 lbs.

*Specifications subject to change without notice

Standard sizes and colors shown. Custom specifications and sizing available upon request.

866-917-9017 | john@americanmadedumpsters.com | americanmadedumpsters.com